

Features

- Hot-pluggable 1600G OSFP DR8 form factor
- Compliant with OSFP MSA, close top housing
- Compliant with CMIS Rev 5.2
- Built-in DDMI function
- Silicon photonics MZM solution
- 8x106.25GBd PAM4 electrical and optical interface
- Maximum link length of 500m G.652 SMF fiber
- Single 3.3V power supply
- Operating case temperature 0°C to +70 °C
- Power dissipation < 25W
- Dual MPO-12 APC receptacles
- Compliant with RoHS 2.0

Applications

- Data center and cloud networks
- 1600G Ethernet and InfiniBand XDR
- Support applications: 1x1600G,2x800G,4x400G, 8x200G

Order Information

Table 1-Order Information

Part No.	Bit Rate (Gbps)	Wavelength (nm)	Distance	Fiber Type	DDMI	Connector	Temp
TLP-OSFP-1.6T-DR8	1700	1310	500m	SMF	YES	Dual MPO-12 APC	0~70°C

Note:

1. 500m G.652 SMF fiber
2. Case Temperature

Absolute Maximum Ratings

Table2- Absolute Maximum Ratings

Parameter	Symbol	Min.	Typical	Max.	Unit	Notes
Supply Voltage	V _{cc}	-0.3	-	3.6	V	
Storage Temperature	T _s	-40	-	+85	°C	
Operating Humidity	RH	5	-	+95	%	1
Control Input Voltage	V _I	-0.3	-	V _{cc} +0.3	V	
RX damage threshold, each Lane	-	5	-	-	dBm	

Note:1 No condensation

Recommended Operating Conditions

Table 3- Recommended operating Conditions

Parameter	Symbol	Min.	Typical	Max.	Unit	Notes
Operating Case Temperature	T _c	0	-	70	°C	
Power Supply Voltage	V _{cc}	3.135	3.3	3.465	V	

Power Dissipation	P_{diss}	-	-	25	W	
Supply Current	I_{cc}	-	-	8	A	
Pre-FEC Bit Error Ratio	-	-	-	2.4×10^{-4}	-	
Post-FEC Bit Error Ratio	-	-	-	1×10^{-12}	-	1
Link Distance (G.652 SMF)	-	2	-	500	m	2

Note:

1. FEC provided by host system
2. FEC required on host system to support maximum distance

Electrical Characteristics

Table 4- Electrical Characteristics

Parameter	Symbol	Unit	Min	Typ	Max	Notes
Transmitter						
Signaling Rate,each Lane	-	Gbaud	106.25±100 ppm			
Modulation Format	-	-	PAM4			
Single-Ended Voltage Tolerance	-	mV	-400	-	1400	
Amplitude Tolerance	-	mV	-	-	1000	
Differential Termination Mismatch	-	%	-	-	10	
DC Common-Mode Voltage Tolerance	-	mV	-50	-	1050	
Receiver						
Signaling Rate,each Lane	-	Gbaud	106.25±100 ppm			
Modulation Format	-	-	PAM4			
Differential Output Voltage Peak to Peak	$V_{out,ppd}$	mV	-	-	1200	
Differential Termination Mismatch	-	%	-	-	10	
DC Common-mode Voltage Tolerance	-	mV	-50	-	1050	

Table 5-Optical Characteristics

Parameter	Symbol	Unit	Min	Typ	Max	Notes
Transmitter						
Signaling Rate,each Lane	-	Gbaud	106.25±100 ppm			
Modulation Format	-	-	PAM4			
Center Wavelength	λ_c	nm	1304.5	1311	1317.5	
Side-mode Suppression Ratio	SMSR	dB	30	-	-	
Average Launch Power, each Lane	TxAOP	dBm	-3.3	-	4	1
Outer Optical Modulation Amplitude, (OMA _{outer}), each Lane	OMA	dBm	-0.3	-	4.2	
Transmitter and Dispersion Eye Closure for PAM4, each Lane	TDECQ	dB	-	-	3.4	
Extinction Ratio, each lane	ER	dB	3.5	-	-	
Transmitter overshoot and undershoot	-	%	-	-	22	
Transmitter power excursion	-	dBm	-	-	2.3	
Average Launch Power of OFF Transmitter, each lane	TOFF	dBm	-	-	-15	
RIN _{21.4OMA}	RIN	dB/Hz	-	-	-136	
Optical Return Loss Tolerance	ORL	dB	-	-	21.4	
Transmitter reflectance	-	dB	-	-	-26	2

Receiver						
Signaling Rate,each Lane	-	Gbaud	106.25±100 ppm			
Modulation format	-	-	PAM4			
Receive Wavelength Range	λ_c	nm	1304.5	1311	1317.5	
Average Receive Power, each lane	RxAOP	dBm	-6.3	-	4	
Receive Power (OMAouter), each Lane	RxOMA	dBm	-	-	4.2	
Receiver sensitivity (OMAouter), each lane for TECQ < 0.9 dB for 0.9 dB ≤ TECQ ≤ SECQ	SENOMA	dBm	-	-	-3.4 -4.3+TECQ	3
Receiver Reflectance	-	dB	-	-	-26	
LOS Assert	LOS _{Ast}	dBm	-	-	-15	
LOS De-Assert	LOS _{De-Ast}	dBm	-	-	-9	
LOS Hysteresis	LOS _{Hys}	dB	0.5	-	-	

Note:

1. Average launch power, each lane (min) is informative and not the principal indicator of signal strength. A transmitter with launch power below this value cannot be compliant; however, a value above this does not ensure compliance.
2. Transmitter reflectance is defined looking into the transmitter.
3. Pre BER = $6.4E^{-5}$ at TP3.

Digital Diagnostic Specifications

Table 6-Digital Diagnostic Characteristics

Parameter	Symbol	Unit	Min	Max	Notes
Temperature monitor absolute error	DMI_Temp	degC	-3	3	Temperature range 0 to 70°C
Supply voltage monitor absolute error	DMI_VCC	V	-0.1	0.1	Voltage range 3.135 to 3.465V
Channel TX power monitor absolute error, each lane	DMI_TX_Ch	dB	-3	3	Tx power range -3.3 to 4dBm
Channel Bias current monitor, each lane	DMI_Ibias_Ch	mA	-10%	10%	Ibias range 80 to 480mA
Channel RX power monitor absolute error, each lane	DMI_RX_Ch	dB	-3	3	Rx power range -6.3 to 4dBm

Recommended Interface

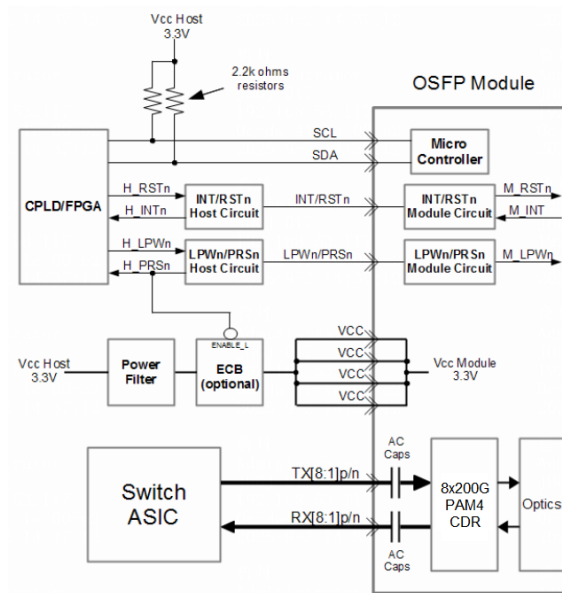

Figure 1 Recommended Interface Circuit

Pin arrangement

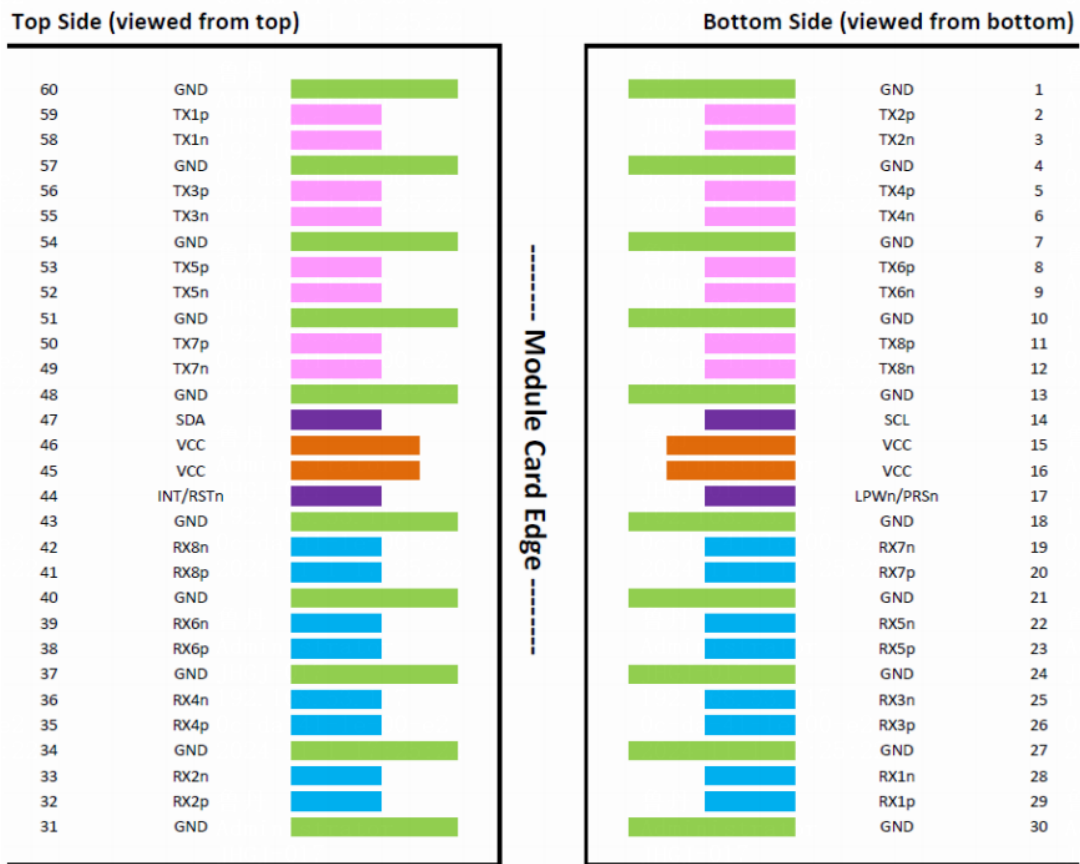

Figure 2 Pin View

Table 7-Pin Function Definitions

Pin#	Symbol	Description	Logic	Direction	Plug Sequence
1	GND		Ground		1
2	TX2p	Transmitter Data Non-Inverted	CML-I	Input from Host	3
3	TX2n	Transmitter Data Inverted	CML-I	Input from Host	3
4	GND		Ground		1
5	TX4p	Transmitter Data Non-Inverted	CML-I	Input from Host	3
6	TX4n	Transmitter Data Inverted	CML-I	Input from Host	3
7	GND		Ground		1
8	TX6p	Transmitter Data Non-Inverted	CML-I	Input from Host	3
9	TX6n	Transmitter Data Inverted	CML-I	Input from Host	3
10	GND		Ground		1
11	TX8p	Transmitter Data Non-Inverted	CML-I	Input from Host	3
12	TX8n	Transmitter Data Inverted	CML-I	Input from Host	3



13	GND		Ground		1
14	SCL	2-wire Serial interface clock	LVC MOS-I/O	Bi-directional	3
15	VCC	+3.3V Power		Power from Host	2
16	VCC	+3.3V Power		Power from Host	2
17	LPWn/PRSn	Low-Power Mode / Module Present	Multi-Level	Bi-directional	3
18	GND		Ground		1
19	RX7n	Receiver Data Inverted	CML-O	Output to Host	3
20	RX7p	Receiver Data Non-Inverted	CML-O	Output to Host	3
21	GND		Ground		1
22	RX5n	Receiver Data Inverted	CML-O	Output to Host	3
23	RX5p	Receiver Data Non-Inverted	CML-O	Output to Host	3
24	GND		Ground		1
25	RX3n	Receiver Data Inverted	CML-O	Output to Host	3
26	RX3p	Receiver Data Non-Inverted	CML-O	Output to Host	3
27	GND		Ground		1
28	RX1n	Receiver Data Inverted	CML-O	Output to Host	3
29	RX1p	Receiver Data Non-Inverted	CML-O	Output to Host	3
30	GND		Ground		1
31	GND		Ground		1
32	RX2p	Receiver Data Inverted	CML-O	Output to Host	3
33	RX2n	Receiver Data Non-Inverted	CML-O	Output to Host	3
34	GND		Ground		1
35	RX4p	Receiver Data Inverted	CML-O	Output to Host	3
36	RX4n	Receiver Data Non-Inverted	CML-O	Output to Host	3
37	GND		Ground		1
38	RX6p	Receiver Data Inverted	CML-O	Output to Host	3
39	RX6n	Receiver Data Non-Inverted	CML-O	Output to Host	3
40	GND		Ground		1
41	RX8p	Receiver Data Inverted	CML-O	Output to Host	3
42	RX8n	Receiver Data Non-Inverted	CML-O	Output to Host	3
43	GND		Ground		1
44	INT/RSTn	Module Interrupt / Module Reset	Multi-Level	Bi-directional	3
45	VCC	+3.3V Power		Power from Host	2
46	VCC	+3.3V Power		Power from Host	2
47	SDA	2-wire Serial interface data	LVC MOS-I/O	Bi-directional	3
48	GND		Ground		1
49	TX7n	Transmitter Data Non-Inverted	CML-I	Input from Host	3
50	TX7p	Transmitter Data Inverted	CML-I	Input from Host	3
51	GND		Ground		1
52	TX5n	Transmitter Data Non-Inverted	CML-I	Input from Host	3
53	TX5p	Transmitter Data Inverted	CML-I	Input from Host	3
54	GND		Ground		1
55	TX3n	Transmitter Data Non-Inverted	CML-I	Input from Host	3
56	TX3p	Transmitter Data Inverted	CML-I	Input from Host	3
57	GND		Ground		1
58	TX1n	Transmitter Data Non-Inverted	CML-I	Input from Host	3
59	TX1p	Transmitter Data Inverted	CML-I	Input from Host	3
60	GND		Ground		1

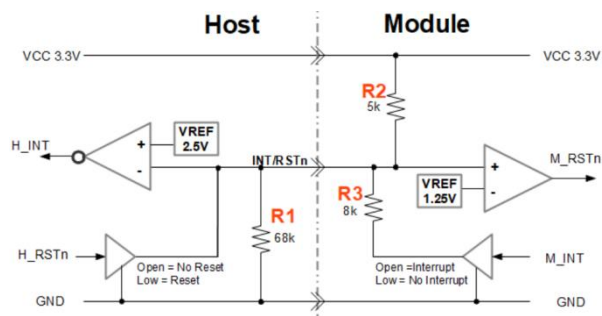

Figure 3, INT/RS Tn circuit

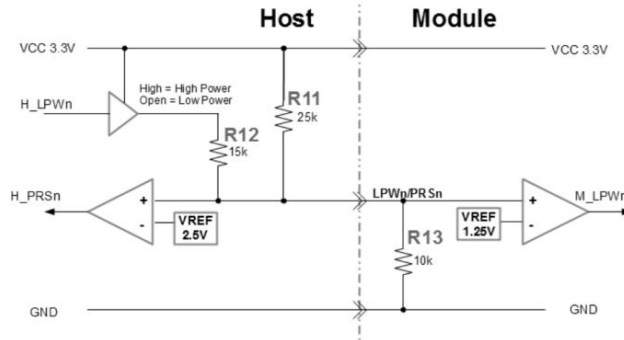

Figure 4 LPWn/PRSn circuit

Memory Map

Compatible with CMIS rev 5.2.

Optical interface arrangement

The optical port is dual MPO-12 APC connector, with fiber lane assignments as shown in Figure 5.

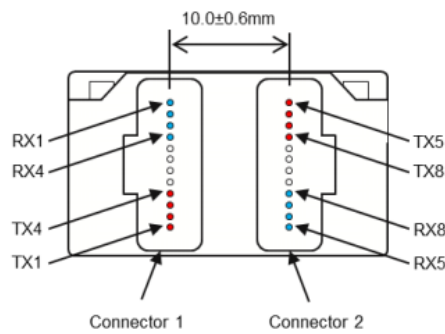

Figure 5 Optical interface arrangement.

Mechanical

1600G OSFP DR8 transceivers are compatible with OSFP Module Specification Rev5.2 for pluggable form factor module.

Unit mm

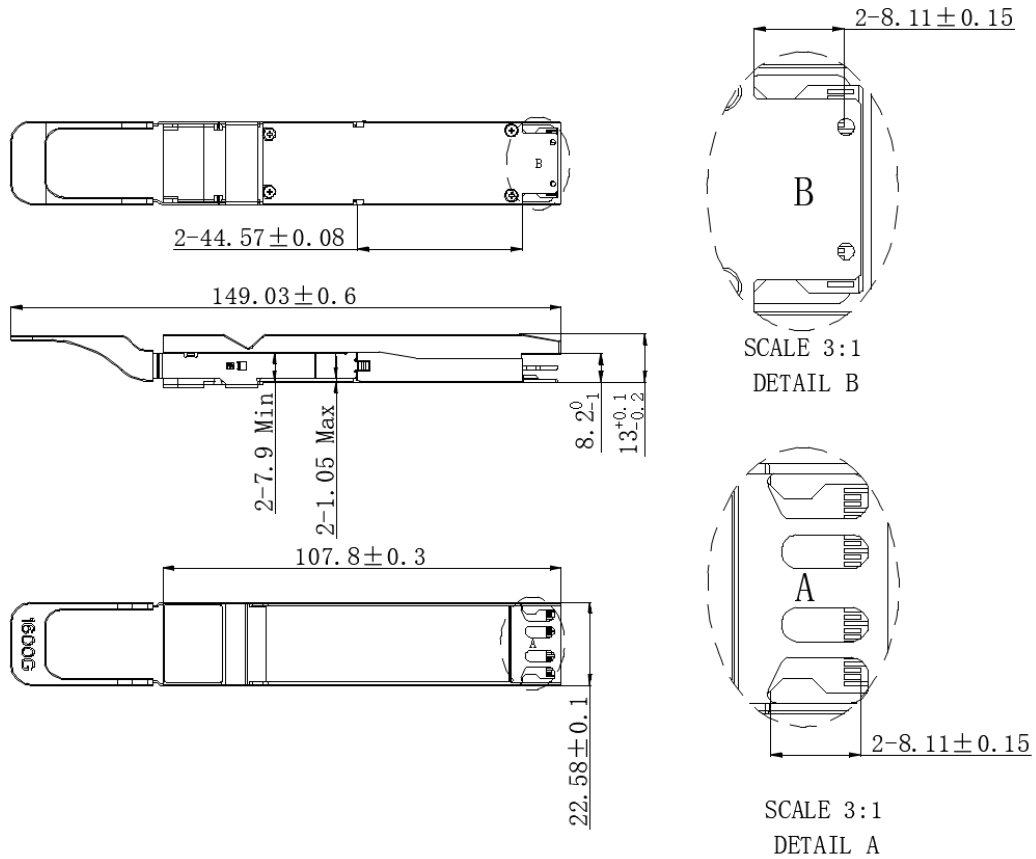

Figure 6 Mechanical Diagram

Warnings

Handling Precautions: This device is susceptible to damage as a result of electrostatic discharge (ESD). A static free environment is highly recommended. Follow guidelines according to proper ESD procedures.

Laser Safety: Radiation emitted by laser devices can be dangerous to human eyes. Avoid eye exposure to direct or indirect radiation.

Hui Zhu

ZE Solution – Hui Zhu

Email: info@zesolution.de

<https://www.zesolution.de>

Add: Schellingstraße 109a, 80798 München, Germany